



# HOW TO MEASURE YOUR DESK FOR A TRIPLE TOOL RAIL DESK SCREEN

Premium Acoustic and Glazed Desk Screen Ranges

To ensure that the desk screen you order fixes to your desk correctly it is important that you measure your desk accurately. This guide is for our triple tool rail desk screens in the Premium Acoustic and Glazed Desk Screen Ranges.

The standard clamp we supply with our desk screens is a 'C' shaped clamp and adjusts to fit desks which are 18-32mm thick. This clamp needs a clearance of 30mm on top and underneath the desk. If there are any obstructions under the desk where the clamp will fit, such as leg brackets, then you need to include these in the measurement - See diagrams.

If your desk is more than 32mm thick, or there are obstacles where the clamps need to fit, then please contact us on **01234 676767** for other clamp options. Please note there may be a charge for substitute clamps.

**Call:** 01234 676767

**Email:** sales@officescreens.co.uk

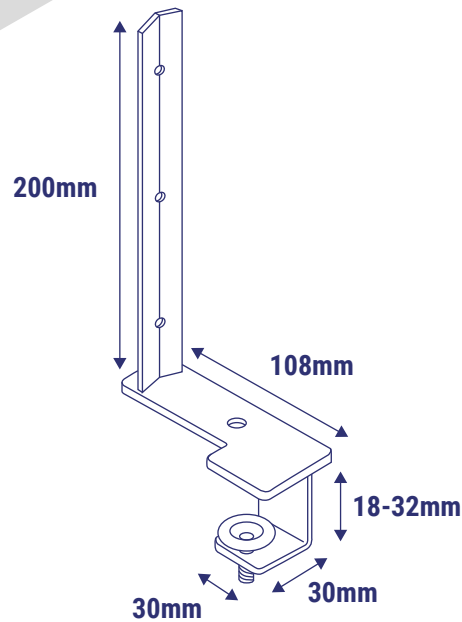

## DESK MEASUREMENTS

Please provide measurements for sections **A**, **B (1&2)** and **C**  
For assistance call us on **01234 676767**

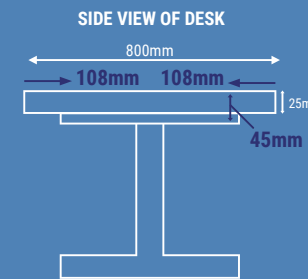
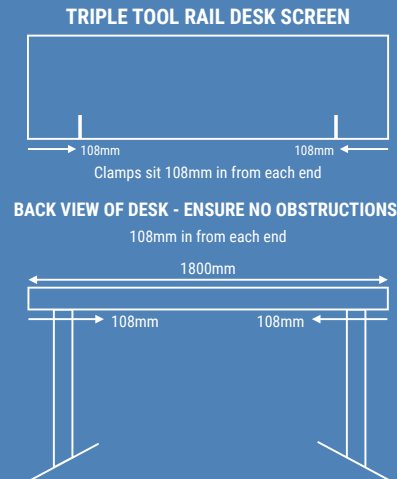
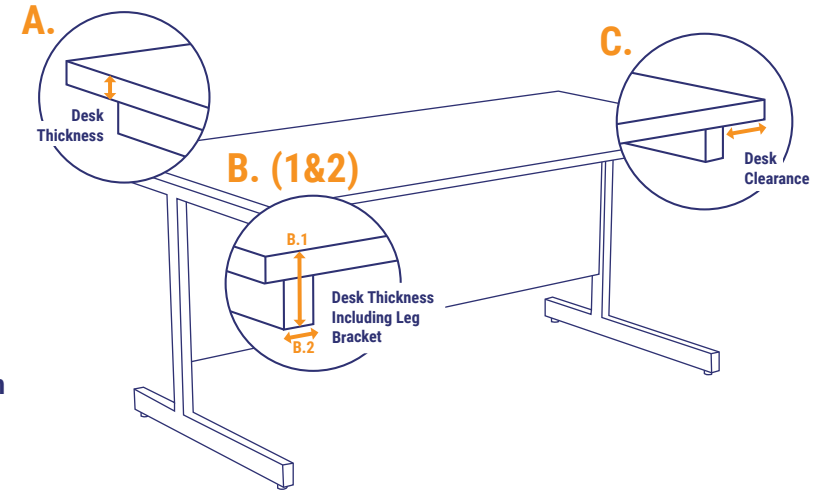

Clamps are fixed to the end of each screen and cannot be moved. For our triple tool rail desk screens, clamps are fitted **108mm** in from each end. Please ensure that you measure this distance from the edge of your desk to ensure there are no obstacles in the way, e.g. desk legs, brackets.

### For This Example:

There is an obstruction of a leg bracket **108mm** in from the end of the desk. Therefore you need to include this when measuring desk thickness. You will need a clamp to fit a **45mm** thick desk.